

CIS 30 DA2

ZD4i RF Multi Master Controller

Product description

- First Zhaga-D4i certified control device
- Monitor and control of public lighting supporting the Zhaga-D4i standard
- Powered by AUX Power supply as specified by the DiiA
- Low energy consumption using device to device IPv6/6LoWPAN technology
- Supporting the 868 MHz narrow band frequency
- GPS version for easy commissioning by visual representation in the user interface and acting as a master clock
- For use in full self-healing mesh networks with up to 300 nodes
- Fast data rate transmission with up to 100 kbps
- Integrated ambient light measurement
- Ready for Zhaga book 18 Ed. 2 receptacle for easy and flexible installation to luminaire
- Lifetime up to 100,000 h at $t_c = 72\text{ }^\circ\text{C}$
- 8 years guarantee in combination with Tridonic LED driver PRE3 (other case 5 years guarantee)

Housing properties

- Casing: Transparent smoke grey
- Type of protection IP66
- Impact protection \leq IK09

Benefits

- **Innovative:** First RF Multi-Master Controller based on Zhaga receptacle using Paradox IPv6 6LoWPAN mesh-technology
- **User friendly:** Fast and easy connectivity upgrade of Luminaire equipped with Zhaga Book 18 Ed. 2 interface
- **Reliable:** Self healing mesh-network for a stable and secured operation
- **Safe:** Pressure equalizing membrane to handle quick temperature changes in outdoor conditions

Typical applications

- Urban Cities focused on Streetlight with a Zhaga interface to build up multi networks



Standards, page 4

Wiring diagrams and installation examples, page 5



CIS 30 DA2



Smart City Plattform



Central Management System

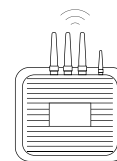

Gateway (Data Concentrator)

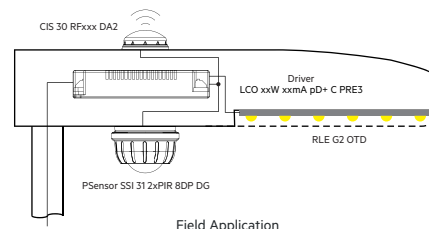

Field Application

System overview



CIS 30 DA2

ZD4i RF Multi Master Controller

Technical data

Supply voltage ^①	24 V
Current consumption average	12 mA
Current consumption pulsed	15.5 mA
Wire length for DALI and power supply	≤ 3 m
Power consumption average	0.29 W
Power consumption pulsed	0.37 W
Starting time ^②	30 s
Mounting hole	acc. to Zhaga book 18 Ed. 2
Type of installation	Zhaga book 18 Ed. 2 socket
Max. output power radio transceiver	14 dBm
Max. radio range	100 m
Radio receiver sensitivity	if -99 dBm = 1 % BER at 100 kbps
Radio protocol	802.15.4 g - 6LoWPAN
Data rate	100 kbit/s
Data encryption	AES-128
NFC	Yes
Capable for firmware update	Yes
Capable for mesh-network ^③	Up to 300 nodes
Ambient temperature t_a	-40 ... +70 °C
Vent humidity range	0 - 90 %
t_c	72 °C
Storage temperature	-40 ... +85 °C
Dimensions $\varnothing \times H$	$\varnothing 79.7 \times 38.5$ mm
Dimensions with dust and dirt protection $\varnothing \times H$	$\varnothing 82.7 \times 43.4$ mm
Housing material top	PC polycarbonate
Housing material body	PBT
Housing colour top	Transparent smoke grey
UV resistance	f1
Type of protection	IP66
Impact protection rating	≤ IK09

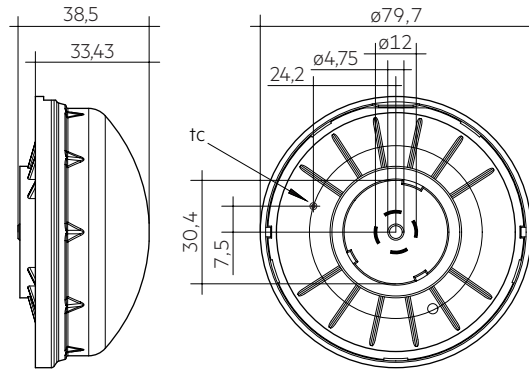

Dimensions without dust and dirt protection

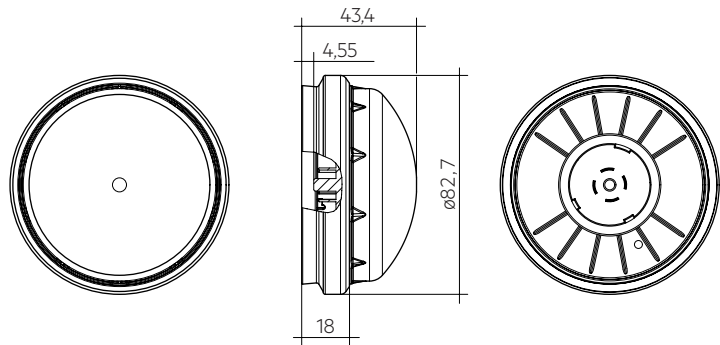

Dimensions with dust and dirt protection

Ordering data

Type	Article number	Radio transceiver operation frequency	Packaging carton	Weight per pc.
CIS 30 RF868 DA2	28002647	868 MHz	60 pc(s).	0.07 kg
CIS 30 GPS RF868 DA2	28003929	868 MHz	40 pc(s).	0.07 kg

^① Only AUX power supply as specified by DiiA.

^② Starting time can also be longer, depending on the Mesh size and amount of connected devices to the node.

^③ In combination with the Tridonic group control system, maximum 60 nodes are supported.

ACU Z18 Set (Zhaga book 18 Ed. 2 receptacle)

Product description

- Set consisting of receptacle, lock washer and mounting nut (ACU Z18 REP 4PIN)
- Designed for street lighting control
- Compliant with Zhaga book 18 Ed. 2
- Optional IP66 with sealing cap (ACU Z18 CAP IP66)
- UL UV-f1 rated for outdoor use
- IK09 high impact resistant
- For more details see data sheet ACU Z18 Set



Housing properties

- Casing receptacle: PBT
- Type of protection IP20

Interfaces

- Supplies Zhaga book 18 Ed. 2 contact system

ACU Z18 REP 4PIN + ACU Z18 CAP IP66

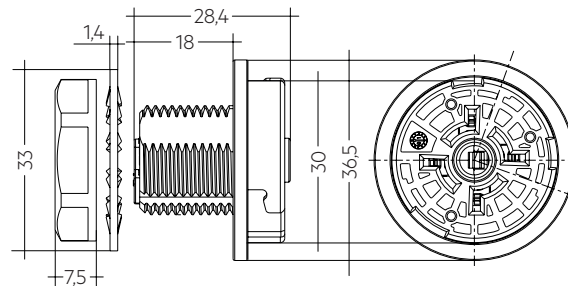

ACU Z18 REP 4PIN

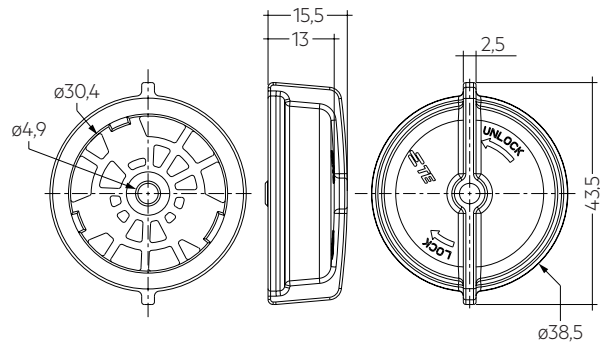

ACU Z18 CAP IP66

Ordering data

Type	Article number	Packaging bag	Weight per pc.
ACU Z18 REP 4PIN	28003209	100 pc(s).	0.008 kg
ACU Z18 CAP IP66	28003208	100 pc(s).	0.020 kg

1. Standards

EC 1907/2006
 RED – 2014/53/EU
 ETSI EN 300 220-1
 ETSI EN 300 220-2
 ETSI EN 300 330-1
 ETSI EN 300 330-2
 ETSI EN 301 489-1
 ETSI EN 301 489-3
 EN 61347-1:2015
 EN 61347-2-11:2014
 EN 55015:2014
 EN 61547:2009
 EN 50364:2010
 EN 62311:2008
 EN 62386-101 Ed.2
 EN 62386-103 Ed.1

1.1 DALI note



RFNode only applicable for DALI installations according to EN 62386-101 Ed.2.

1.2 D4i note

D4i luminaire-mounted control devices (part 351) = Type B

1.3 Glow wire test

according to EN 61347-1 passed with 850 °C.

1.4 Note system test

All components of CIS 30 RF system must be DALI-2 certified and listed on the DIIA web-page.
 CIS 30 RF system was tested with Tridonic DALI-2 components only.
 Check compatibility yourself before installing, if Tridonic DALI-2 components are not used.

2. Common

The RF multi-master controller is one of the first connectivity nodes developed on Paradox innovative 6LoWPAN technology to monitor and control outdoor lighting. The asset management of different luminaires is becoming easier with newest standards coming from Zhaga and DiiA.

With its release of DALI part 250-253 the controller covers the latest standards for improved control functionality and monitoring different parameter like luminaire data, energy data, diagnostic and maintenance.

The innovative interface design of the RF Node enables easy, toolless and fast plug and play by supporting the Zhaga book 18 Ed. 2.

The RF nodes build up its mesh-network autonomously (full self-healing) and can cover a distance of 100 m to neighbor nodes. With up to 6 hops (bridge between nodes and Gateway) the connectivity to Paradox Gateway can then operate with a optimized network up to 300 nodes in a urban area. In combination with the Tridonic Group Control System where no central Gateway is needed up to 60 nodes are supported.

Furthermore a real-time clock supports accurate dimming schedules which can be set remotely by the central management or with the Tridonic Group Control System even with specific event.

Together with a motion sensor integration at the luminaire the RF Multi Master Controller can perform light on demand and override defined profiles. The integrated photocell measuring the ambient light level allowing standalone operation in case of network problems.

Next to its robust design and long lifetime the IP66 and IK09 rating complement an excellent protection against harsh outdoor environment.

The GPS Node provides more convenience during commissioning by providing the correct position on the graphical user interface, so that the user does not have to spend time setting the Node to the correct geographical position.

The GPS Nodes also can acts as a master clock within the 6LoWPAN mesh, providing the correct time to the network, if configured as master clock. At least one GPS Node is required in a Group Control 6LoWPAN network. Since the benefit of a GPS Node is much higher, it is recommended to use only GPS Nodes in your Group Control network and thus use all the advantages of the GPS Node.

3. Installation



Do not connect the RFNode to the mains.

It is supplied directly via the AUX power supply.

- DALI is not SELV. The installation instructions for mains voltage therefore apply.
- For a correct RFNode operation use the device only within the ta window.
- Ensure correct assembly and locking of the RFNode.
- Other RF signals may cause disturbances to the RFNode communication.
- The RFNode will keep the correct time stored for up to two days if not powered. Still if the master clock is not active in this time-frame the time may drift.

OTD system overview:

The RFNode is optimized to be used in combination with Tridonic PSensor and the Streetlight LED driver PRE3 with internal power supply. Following illustration visualizes the wiring of the components inside the luminaire.



Maximum allowed wire-length for DALI and power supply = 3 m.

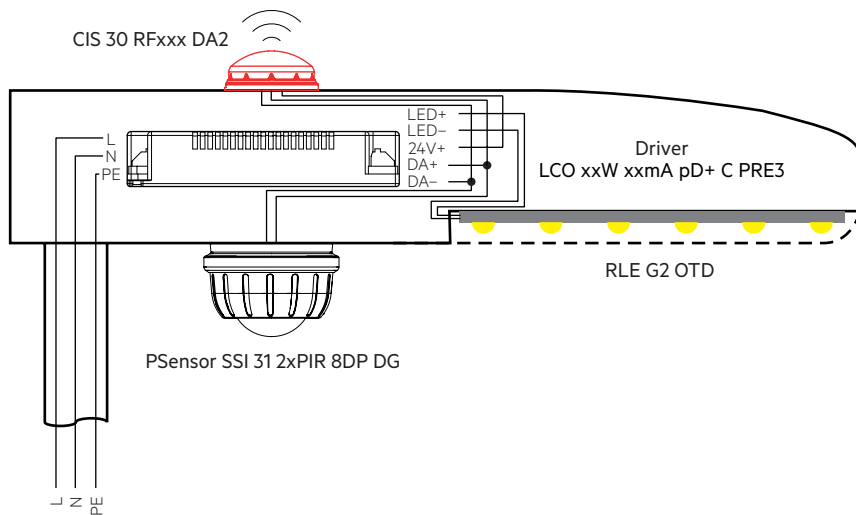

The RFNode supports the Zhaga connectivity standard for Plug&Play luminaire extensions. This allows a toolless and flexible integration in luminaires.

The connection interface is designed according to Zhaga book 18 Ed. 2. A single node can manage up to 8 drivers and 2 DALI-2 input devices (motion or light sensors) or push button interfaces.

Update the RFNode via the Tridonic groupCONTROL Programmer. An overview of the functions of the latest version is available in the release note for the RFNode firmware.

Pin assignment RFNode

Pins	Assignment
Pin 1	+ 24 V
Pin 2*	DA- / ground for 24 V and general Digital I/O
Pin 3*	DA+
Pin 4	General I/O, not connected

* The receptacle installed inside the luminaire has to be designed according to Zhaga book 18 Ed. 2 and inside the luminaire the polarity has to be wired correctly. The polarity is mandatory for function of the device because ground is shared for DALI and 24 V power supply.



Use the same pin assignment for the Zhaga connector pins mounted in the luminaire.

3.1 Mounting:

3.1.1 Installation on luminaire:

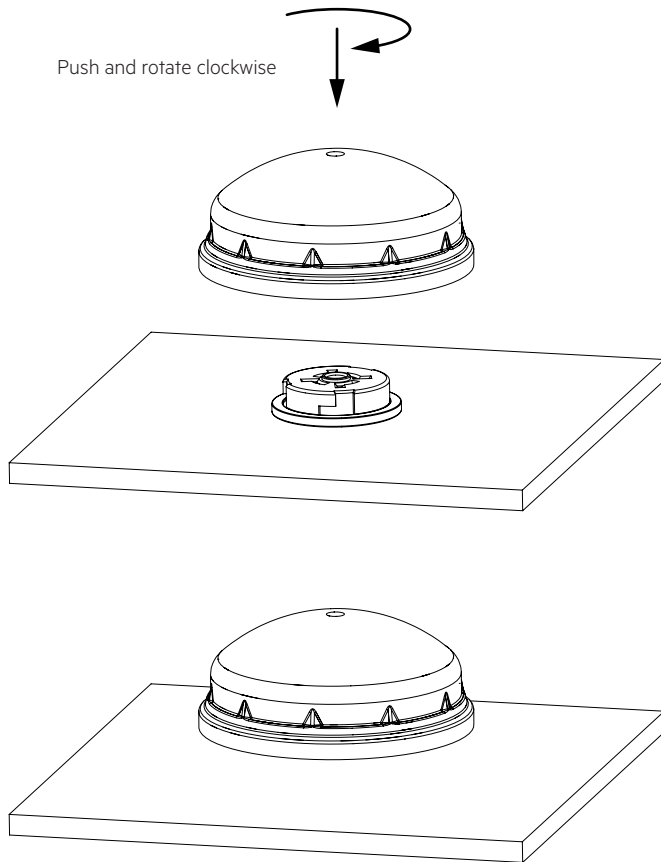

! The RfNode must lock. Make sure that the dust and dirt protection, is not bent, no foreign parts between the seal and the fixture housing are located and that the protection fits the fixture.

3.2 Placement

Maximum radio range may be reduced if objects are located between the RfNodes or the RfNode is covered with dirt, dust, foliage and other impurities.

Max. radio range:

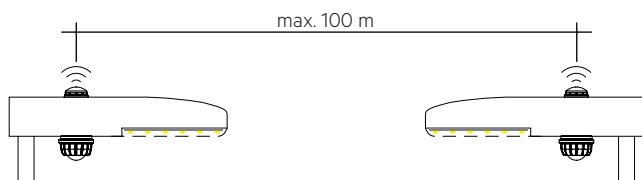

! The range of the communication signal is depending on the environment e.g. buildings, trees or bridges in between the RfNodes and needs to be tested and approved in the field.

! To ensure a good radio connection, do not cover the RfNode with any materials!

3.3 Position of NFC and radio antenna

Device equipped with NFC which will allow additional features in the future.

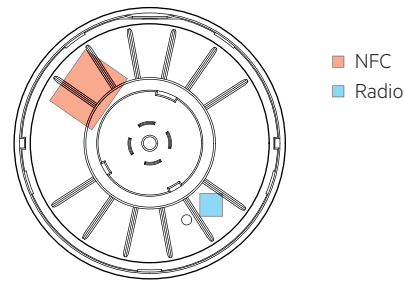

3.4 QR Code

Device has 3 QR Codes:

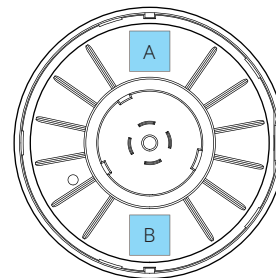

QR Code A:
Provides specific Tridonic product information.

QR Code B:
Provides product specific information like the MAC address.

QR Code C:
This QR Code is placed on the top of the RfNode and is an additional sticker. It provides the same information as QR Code B. This QR Code has to be used during the commissioning. When scanned via the Paradox App (available in iOS and Android store) geographical information from the Luminary will be send to the central management system. This QR Code has to be stucked behind the Luminary pole maintenance door. This makes later maintenance work possible without the need of direct access to the RfNode.

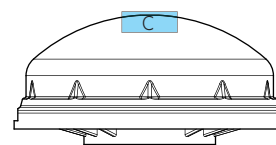

3.5 Installation process

- ① Scan QR Code C (with Paradox App).
- ② Stick QR Code C behind the Luminary pole maintenance door.
- ③ Install the RFNode.

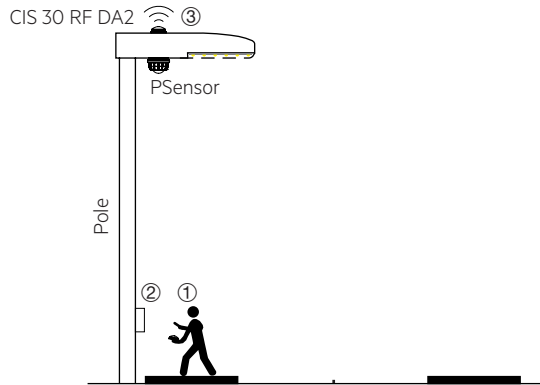

4. Miscellaneous

4.1 Disposal of equipment



Return old devices in accordance with the WEEE directive to suitable recycling facilities.

4.2 Additional information

Additional technical information at www.tridonic.com → Technical Data

Guarantee conditions at www.tridonic.com → Services

Lifetime declarations are informative and represent no warranty claim.
No warranty if device was opened.